



THE KNIGHT FLYER



Jan – Feb - Mar

2012

Christmas Party 2011

The lure of pizza and wings always draws a significant number of club members to the December meeting.

At least forty showed up for the annual Christmas Party along with a few family members, making this one of our best attended meetings.

This year, instead of the usual transmitter, a cash award of \$200 was presented.

Mike Woelful and Walt Meyer volunteered to take over the New Pilot program. Bob Rodgers and Don Moffitt were thanked for their efforts administering this key activity.

Most of the current officers elected to stay in their positions.

Greg Stromecki was selected to replace outgoing secretary, Dave Savini.

Bill Hauth was elected to the board. A picture of all of our officers can be seen on Page 2.

No sooner was business out of the way, when out in the hall there arose such a clatter, that we sprang from our chairs to see what was the matter.

The aroma of pizza told the story. The line soon formed and before long everyone had a full plate.

There was a vast array of desserts and everyone settled down to discuss their latest model project or relive those enjoyable moments of yester-year.



The pizza line begins to swarm

While members were voting for the slate of candidates, the presentation of annual awards took place.

The annual “Paas” award went to Hal Hauser. This eagerly sought honor is named for Herb, it’s first recipient.

Greg Stromecki won the 2nd annual Flying Knight’s Appreciation Award.

Tom Woolverton grabbed the “Tree Hugger” Award and Dave Kobi snagged the “Shelter Fly-by Award.

The annual Christmas Prize went to Don Domon.



Don Moffitt & Bob Rodgers sample pizza

Inside:

- New Officers P-2
- Prez letter P-3
- Secrets of SS..... P-4
- Chili Fly event.. P-6
- Fall Auction P-7
- Electric Fly event,,,,,..... P-7

The Knight Flyer

Membership dues **must** be received before **Jan. 13, 2012** or you will be dropped from the roster.

Extension by request only. (Call 699-4716).

If you are not able to see the Treasurer, please use the form below to renew your membership by mail.

Remember, flying privileges at the Nike Site and the North Collins fields are restricted to club members only!

Return form along with **payment** and a **copy of 2012 AMA card** to Ray Barren, 7330 Kent Road, Little Valley, NY 14775.

2012 Dues Renewal Form

Name: _____

Address: _____

City: _____ State _____ Zip: _____

Phone: _____ A.M.A. # _____

Email: (if you have one.): _____

Make Plans for Toledo

This year's Toledo Event will take place on April 13, 14 & 15
\$10 / person / day
Seagate Center

Don't miss our Famous Chinese Auction

Feb. 3rd
Benefits NC Field Fund.
A great opportunity to unload your ~~junk~~ unneeded items.

Note: ECC Schedule not yet available. When we get it, you'll get it.

Mall Show

March 2,
3, & 4th

McKinley
Mall
Setup Thu
Mar. 1st.



Flying Knights Officers 2012

Chuck Caruana Vice President, Jim Ehrig President, Ray Barren Treasurer, Greg Stromecki Secretary
Jim Devlin Newsletter Editor, Bob Rodgers Board, Bob Waldraff Board, Bill Hauth Board, Orv Chatwood Board

The Knight Flyer

From the
President's
Desk.....



"To improve is to change; to be perfect is to change often."

Winston Churchill

As we start a new year, I would like to once again thank the members of the Flying Knights for allowing me to lead our club for another year. Last year, I stated that my goal as president is to ensure the standards and traditions of the club are maintained, as well as, introduce new ideas that will focus on increasing membership, providing opportunity for current members to express their own ideas and be more involved with decision making, become cohorts with other local clubs, and most importantly, that you have fun flying. The board and I will continue to ensure these goals are met in 2012.

Once again, we will establish several groups of "leadership teams". I will be working closely with the Board, to determine the responsibility of each team. Areas we will focus on are Training, Safety, Special Events (Scale Rally, Mall Show, Auction, etc.), Grounds & Maintenance, and Field Activities. I will be looking within the membership for the necessary "buy-in" and individuals wanting to take leadership positions.

We welcome two new members

to the board this year. Greg Stromecki will take over as Secretary and Bill Hauth will serve as a board member. I would like to acknowledge the efforts of Dave Savini and Jim Pravel for their work over the past year. Thank you for your dedication. Also, thank you to Don Moffitt and Bob Rodgers for their work with the new member team. They have requested to resign their positions to Mike Wolfel and Walt Meyer.

Our Leadership Team initiatives proved to be successful in 2011. I thank all of the membership for their efforts; without you, none of our events would be successful. I would like to single out a couple of people. First, thank you to Bob Waldraff for his leadership during our annual spring clean-up at the North Collins Field We completed a lot of work in a short period of time, including a complete cleaning of our trailer. Second, Dave Savini secured the new location at the mall. Next, Bill Hauth for his leadership during the Scale Rally. Needless to say it was a tremendous effort to redesign and manage the new flight line. It was one of the clubs most successful rally's. Finally, Greg Stromecki; it would have been a tough auction without him.

I am pleased to see the enthusiasm and continued success of our fun fly's and special events we had last year. Thank you to everyone who volunteered and made them a success.

Continued on Page 6

New Website Tool Finds Old News

Web travelers to the club website will find a new addition.

Stu Brierly, our webmaster has added a new feature to the site that will make it easier to find old news articles and information.

If you are looking for something that you vaguely remember from an old newsletter, simply go to the newsletter page. There you will find a "search box"..

Enter a few words related to the subject that you think may have been in the original article.

A "click" of the button and a

page will appear with links to numerous old newsletters that reference those words.

Among the references presented should be the newsletter article that you are seeking.

By clicking on the reference link, the actual newsletter containing that article will come up on your screen.

This is a handy way to look back through the years for an event or person that you vaguely recall from the past or seek some technical info on a question that you now have.

The Knight Flyer

Slippery Secrets of Spread Spectrum

Everyone remembers when we used to go out to the flying field only to find that someone else was flying on the same frequency.

In fact it seemed like a law of nature that whatever frequency you chose, someone automatically appeared with the same channel.

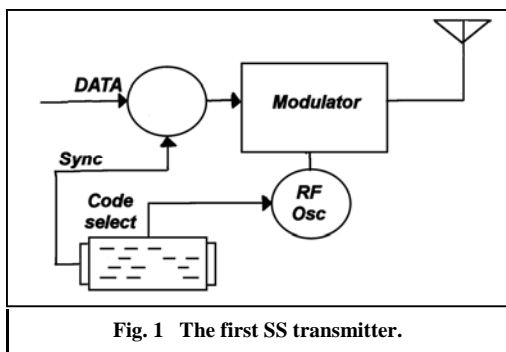

Fig. 1 The first SS transmitter.

It was unthinkable that two people could share the same channel and if a crash occurred, the first words you heard were, "Who the ---- is on my frequency!"

How time, (and Technology) changes.

Now it is common to see a half dozen flyers using the same frequency without interference and with complete reliability.

This is even more evident in the case of indoor flying where a dozen or more pilots all share the same frequency.

Not a pin is in sight.

So what happened? How do these new radio systems work?

Perhaps the easiest way to explain spread spectrum systems is to go back to the original.

Back in the forties, Hedy LaMar, (Yep, the movie star), and musician George Antheils filed a patent for such a system.

Early in the war Japanese navy ships would locate our torpedoes and jam the guidance receivers, knocking them off course.

Using this system the frequency continuously changed. The enemy would be unable to locate the exact frequency, and if they did it would change before they could jam it.

Since Antheils was a musician, the scheme used player piano rolls.

The components were hooked up as shown in Fig. 1. The transmitter was capable of switching to a bunch of different frequencies. The piano roll could be programmed (by changing rolls) to control an oscillator, thereby randomly changing the frequency across the band.

The receiver, Fig 2, also used an identical piano roll to control its local oscillator. By synchronizing the piano rolls, a secure communication system was obtained.

This is an example of a "Frequency Shift Spread Spectrum" or FSSS.

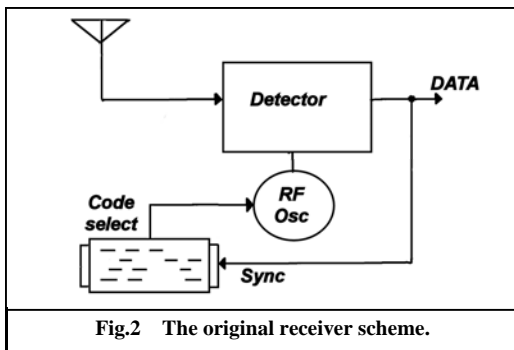

Fig.2 The original receiver scheme.

Because multiple frequencies as shown in Fig. 3, were used in each transmission throughout the band, it was called spread spectrum

For unknown reasons the military did not use this system, but after the war, expanded on the idea and developed secure communications based upon it.

OK, piano rolls are so forties.

The Knight Flyer

Fast forward half a century.

Modelers have the same problem. Whenever someone turns on the same channel while you are flying, your plane is toast.

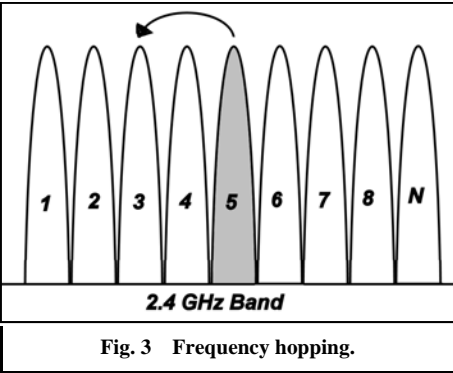

Fig. 3 Frequency hopping.

Our current systems are “narrow Band”.

The narrow band signals interfere with each other and the data gets confused.

Electronics has advanced to the point where entire circuits are contained in a tiny chip. And the world has gone digital. No need for bulky piano rolls.

An electronic number generator randomly selects the frequency and sends it on to the receiver. The two components set up a handshake and track each other.

The frequency hops rapidly around the band. As often as 500 times a second, while the receiver is locked to it and tracks it.

Meanwhile, all other channels are empty. Another transmitter/receiver combo can use these vacant channels

It can even use the channel that was just in use by the first transmitter, since that channel rapidly becomes vacant.

Frequency hopping is just one of the methods that can be used by Spread spectrum.

A different scheme is used wherein the entire band is transmitted as a single broadband frequency.

Instead of the frequency hopping, the modulation plus a code flips from channel to channel within the band.

The code is combined with the signal and both are used to modulate the transmitted frequency.

When this broadband signal is received, the code is stripped and used to lock on to the correct channel.

Even though many transmitters are in use, the receiver tracks only the specific code that it is bound to.

It ignores any and all other transmitters that are active on the same band. For our situation at the flying field where multiple users are all flying at the same time, this is fantastic improvement over the old way.

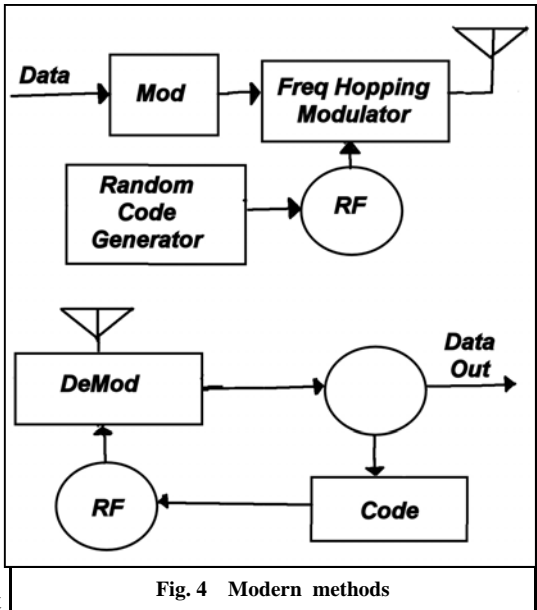

Fig. 4 Modern methods

Providing far better security, far fewer glitches and a better experience for modelers, Spread Spectrum is about as bullet proof as it gets.

The Knight Flyer

Chili Fly

The weather in October can be a tad unpredictable. It was decided to play the Chili Fly by ear.

So when the weekend prognosis looked favorable, the move was made to strike.

Good call. It turned out to be a great day for flying, but lacked that



Kudos to the Chili Cooks



Fascination

Short sleeves and Autumn leaves accompanied the bowls of Chili.

Several species of the signature entree made their appearance.

All in their own way were delicious. Accompanied of course by dishes and deserts to pass.

A great way to finish the flying season.

Continued from Page 3

Also, thank you to Ray Barren, for once again hosting an event. I encourage everyone to take advantage of using our fields. You are welcome to camp, have picnics, parties, etc. It is your field to use, enjoy it!

We have established a calendar for 2012. Please be on the lookout for any changes or additions. I will ensure proper notification is passed along.

If anyone needs to contact me, please call or e-mail as necessary.

Home Phone : 649-2943

Cell Phone : 771-7958

E-mail : jehrigiii@gmail.com

Please feel free to contact me with any ideas, questions, or concerns you may have.

I look forward to your input for the betterment of our club.

Thank you for your support,

Jim Ehrig

Turkey Fly

The field was crowded as everyone tried to get in what might be the last flight of the year.

One can hardly believe the late



Getting ready for Combat

November weather. Days in the 50's and light winds.

Such was the day that the RC Aircrafters held their annual Turkey Fly.

A great exhibition venue was the combat event. About a half dozen flyers put their own planes at great risk by attempting to cut the stringer trailing from each other's plane.

And indeed they did, with several spectacular mid-air crashes. Many a tail was severed to the delight of the crowd.

Meanwhile, the turkey was in the oven. When the time came for dinner, a generous spread was presented consisting of a vast array of dishes brought in by the attendees.

Obituary

In November the club suffered the loss of Hugh Spears.

Hugh is well remembered for his many wood projects that he donated to our club over the years.

Numerous small wooden planes were prizes at the mall shows to children participating in egg carton glider programs, one of his pet activities.

Tissue boxes he made were presented at Christmas parties.



which we use for so many events.

Hugh joined the Knight's after his wife passed away and really enjoyed his membership in the club.



Do I hear 25 dollars?

Fall Auction

With the season winding down most of us look at the remains of the beautiful models that brightened those warm spring days.

They look like they've been rode hard and put away wet, so to speak.

But, might they not be just what someone else is looking for. And what better place to give them a new life than the Autumn Auction.

This year Greg Strumecki debuted as the auctioneer.

Schedule for indoor flying at the Agri-Center

Monday Jan. 9
Monday Mar. 5

Monday Feb. 20
Monday April 9

First Ever Electric Fly

It may have been some remarkable coincidence, but our very first electric fun-fly and breakfast event was blessed with absolutely fantastic weather conditions.

Early in the morning while the sun cast long shadows across the runway, flyers arrived with a large inventory of electric planes.

Even the smallest indoor models were able to take advantage of the day.

Around 9 AM the food put in an appearance. The potatoes, eggs and sausage were excellent.

Amazingly, the light breezes held throughout the day.



Hal Hauser launches indoor plane

This event, spearheaded by Jerry Piscatello, should become an annual event, but such a beautiful flying day could never be guaranteed.

1st Q 2012

Schedule

Fri. 1/13, 2/3,
2/24, 3/16

St. James Church 7:30
New members 6:30

Board Meeting

Tues. 1/10, 1/31,
2/21, 3/13
7:30 pm
Pegasus

Officers

President: Jim Ehrig III
Vice Pres: Chuck Caruana
Secretary: Greg Stromecki
Treasurer: Ray Barren

Board

Bill Hauth Bob Rodgers
Bob Waldruff Orv Chatwood
Editor Jim Devlin

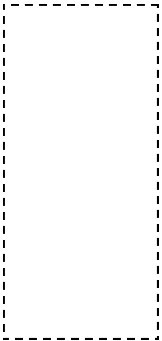

The Flying Knights
c/o 5761 Diana Lane
Lake View, NY 14085



The Flying Knights of Hamburg, NY

Academy of Model Aeronautics - A Chartered Radio Control Flying Club

www.theflyingknights.com

